



STC Series

THREE-PHASE A.C. SYNCHRONOUS ALTERNATOR

三相交流同步发电机



技术参数 TECHNICAL DATA

Model	Output (KW)	Voltage (v)	Current (A)	Power factor (cos)	Poles	Speed r. p. m
STC-2	2	400/230	3.6	0.8	4	1500
STC-3	3	400/230	5.4	0.8	4	1500
STC-5	5	400/230	9	0.8	4	1500
STC-7.5	7.5	400/230	13.5	0.8	4	1500
STC-10	10	400/230	18.1	0.8	4	1500
STC-12	12	400/230	21.7	0.8	4	1500
STC-15	15	400/230	27.1	0.8	4	1500
STC-20	20	400/230	36.1	0.8	4	1500
STC-24	24	400/230	43.3	0.8	4	1500
STC-30	30	400/230	54.1	0.8	4	1500
STC-40	40	400/230	72.2	0.8	4	1500
STC-50	50	400/230	90.2	0.8	4	1500

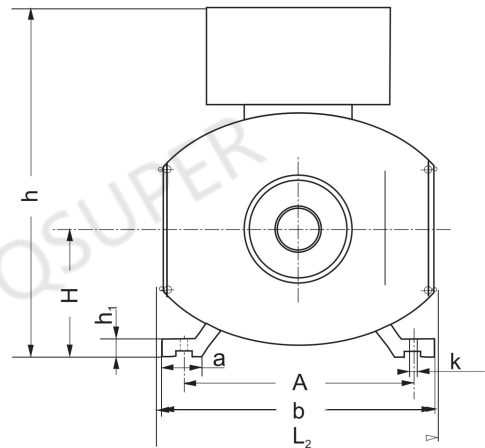
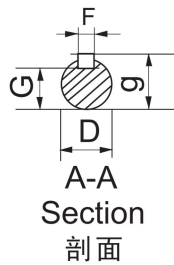
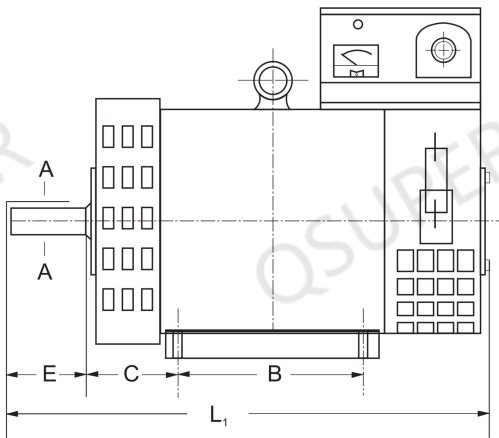

安装尺寸 OVERALL & INSTALLATION DIMENSIONS

Model	Output (KW)	Mounting Dimensions (mm)									Overall Dimensions (mm)						
		A	B	C	D	E	F	G	H	K	a	b	h1	h	L1	L2	g
STC-2	2	216	178	89	32	80	10	27	132	12	34	250	18	400	480	270	35
STC-3	3	216	178	89	32	80	10	27	132	12	34	250	18	400	480	270	35
STC-5	5	254	254	108	38	80	10	33	160	15	50	304	25	445	580	325	41
STC-7.5	7.5	254	254	108	38	80	10	33	160	15	50	304	25	445	580	325	41
STC-10	10	279	203	121	42	110	12	37	180	15	55	334	25	495	610	365	45
STC-12	12	279	203	121	42	110	12	37	180	15	55	334	25	495	610	365	45
STC-15	15	318	228	133	48	110	14	42.5	200	19	60	378	30	545	660	400	51.5
STC-20	20	318	228	133	48	110	14	42.5	200	19	60	378	30	545	660	400	51.5
STC-24	24	318	228	133	48	110	14	42.5	200	19	60	378	30	545	660	400	51.5
STC-30	30	356	286	149	60	140	18	53	225	19	65	421	32	610	770	452	64
STC-40	40	356	286	149	60	140	18	53	225	19	65	421	32	610	770	452	64
STC-50	50	356	311	149	60	140	18	53	225	19	65	421	32	610	810	452	64